

Installation & Operation Manual

Covering -

DB9000C

DB9000C
ROPE



CE



BRITPART



Features

- 3.3Kw (4.5Hp) permanent magnet motor
- Dustproof contactor controls for longer life and improved amperage draw
- Planetary gear system for fast line speed
- Free spooling
- Low electric current
- Automatic load-holding brake
- Power in and power out
- Hardened drum

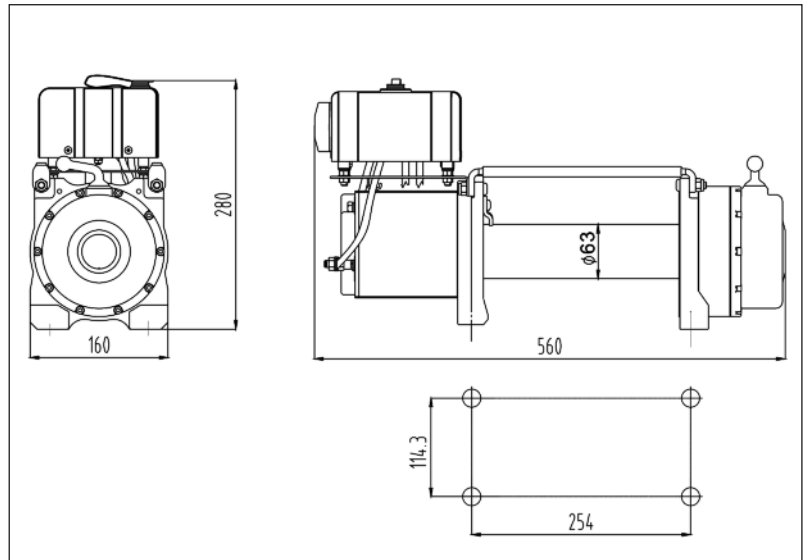

Specifications

- | | | |
|---|-------------------|-------------------|
| • Rated Line Pull - single line | 4,082kgs | 9,000lbs |
| • Gear Reduction Ratio | 212:1 | 212:1 |
| • Motor - permanent magnet - 12 volts | 3.3Kw | 4.5Hp |
| • Drum Size (D x L) | 63 x 228mm | 2.5 x 9" |
| • Rope Supplied - Steel (maximum break force 14,400lbs galvanised aircraft cable) | 9.5mm x 30.5m | 0.38" x 100' |
| • Rope Supplied - Dyneema (maximum break force 25,800lbs) | 11mm x 28m | 0.43" x 91.9' |
| • Overall Dimension (L x W x H) | 560 x 160 x 280mm | 22 x 6.3 x 11" |
| • Mounting Bolt Pattern | 254 x 114.3mm | 10 x 4.5" |
| • Net Weight (Steel / Dyneema) | 38.0kgs / 31.0kgs | 84.0lbs / 72.8lbs |

Performance of 1st Layer

| Line Pull | | Line Speed | | Motor Current |
|-----------|-------|------------|-----|---------------|
| Lbs | Kgs | Fpm | Mpm | Amp |
| 0 | 0 | 9.8 | 3.0 | 50 |
| 2,000 | 907 | 9.8 | 3.0 | 120 |
| 4,000 | 1,814 | 8.9 | 2.7 | 170 |
| 6,000 | 2,722 | 8.2 | 2.5 | 225 |
| 8,000 | 3,629 | 7.2 | 2.2 | 275 |
| 9,000 | 4,086 | 6.1 | 1.9 | 300 |

Line Pull & Rope Capacity by Layer

| Rope Layer | Rated Line Pull | | Rope Capacity | | | |
|------------|-----------------|-------|---------------|--------|--------------|--------|
| | | | Steel Rope | | Dyneema Rope | |
| | Lbs | Kgs | Feet | Metres | Feet | Metres |
| 1 | 9,000 | 4,309 | 15.0 | 5.0 | 12.8 | 3.9 |
| 2 | 7,500 | 3,402 | 38.0 | 11.5 | 29.2 | 8.9 |
| 3 | 6,200 | 2,812 | 64.0 | 19.5 | 49.0 | 15.0 |
| 4 | 5,300 | 2,404 | 95.0 | 29.0 | 71.9 | 21.9 |
| 5 | 4,630 | 2,100 | 100.0 | 30.5 | 91.9 | 28.0 |

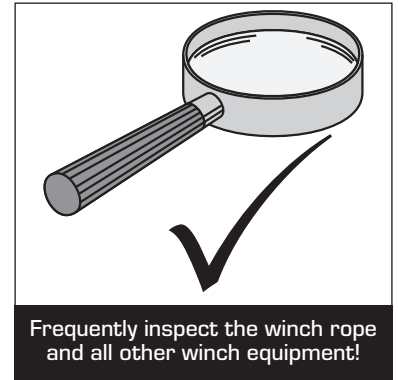

When operating this winch, safety precautions should always be followed to reduce the risk of personal injury and damage to the winch.

• Learn How To Use Your Winch

After the winch has been installed, take some time to practice using the winch so that you are familiar with its operation. Periodically check the winch installation to ensure all nuts and bolts are tight. To ensure proper operation, carefully inspect for any damaged parts before operating the winch. Any damaged part should be repaired or replaced.

• Keep Winching Area Clear

Do not allow people to remain in the area during winching operations. Do not step over a taut wire rope or allow anyone else to do so. A snapped wire rope could cause injury or death. Keep proper footing and balance at all times. Do not reach over or across the winch and/or wire rope or come between the winch and load whilst the winch is in operation.

• Inspect Winch Rope & Equipment Frequently

The winch rope should be inspected for damage that can reduce its breaking strength. A frayed rope with broken strands should be replaced immediately. Never use a wire rope that shows signs of weakening is knotted or kinked. Dyneema rope can be cleaned by unspooling into a bucket of clean water and tumble rope in the water until clean - check the condition. Always replace the rope with one of the correct rating for the winch. Examine the winch before using as components may be affected by exposure to everyday weathering, chemicals, salts and rusts etc.

• Working Area Conditions

Keep the working area well lit. Do not use the winch in the presence of flammable gasses or liquids.

• Keep Children Away

Keep children away from the working area and never let children operate the winch.

• Wear Gloves

When handling or rewinding the wire rope, always use hand protection to eliminate the possibility of cuts caused by burrs and slivers from broken strands.

• Secure Vehicle

Be sure to secure vehicle in position before using the winch and after moving an item with the winch secure the item. Do not rely on the winch to hold it for an extended period as the winch does not have a locking mechanism. Apply blocks (such as a wheel choke) to vehicle when parked on an incline.

• Drum Rope

Do not apply load to winch when the wire rope is fully extended. Always make sure that there are at least 5 complete turns of rope left on the drum before starting to winch. Take care to ensure the wire rope is re-spooled correctly.

• Keep Hands & Fingers Clear Of Wire Rope & Hook When Operating Winch

Never put your finger through the hook when reeling in the last few feet. If your finger gets trapped in the hook or rope you could lose it. Never guide the wire rope under tension onto the drum with your hand. Always keep hands and body away from the fairlead (cable intake slot) when operating the winch.

• Never Hook The Wire Rope Back Onto Itself

Hooking the rope back onto itself creates an unacceptable strain, breaking individual strands, which in turn weakens the entire wire rope.

• Keep Pulling Durations As Short As Possible

The winch is designed for intermittent use and cannot be used in constant duty applications. Do not pull for more than one minute at or near the rated load. If the motor becomes too hot to touch, stop and let it cool off for a few minutes. If the motor stalls then cut off the power immediately.

• Do Not Overload

Always use the winch below its rated capacity for your safety and better performance of the winch. Do not use inappropriate attachments in an attempt to exceed its rated capacity.

• Avoid Continuous Pulls From Extreme Angles

This will cause the rope to pile up at one end of the drum. When feasible, get the rope as straight as possible to the direction of the object.

• Never Operate The Winch Without The Rope Fairlead Fitted

Operator injury or winch damage can result if a fairlead is not installed.

• Stay Alert

Watch what you are doing at all times. Use your common sense. Do not use this winch when you are tired, stressed or when under the influence of drugs, alcohol or medication.

• Disconnect Switch

Rotate switch to stop in an emergency.

• Stay Alert

When servicing, use only identical replacement parts. Use of any other parts will void the warranty.

• Check Winch Is Secure

Be certain that winch is properly bolted to a structure or vehicle that can hold the winch load.

• Use The Right Couplings

Always use the proper couplings when connecting the winch cable to the load.

• Use Horizontally

Never lift items vertically as the winch was designed for horizontal use only. Never lift people or hoist loads over people.

• Inappropriate Attachments

Do not use any inappropriate attachments to extend the length of the winch cable.

• ...And Finally

The warnings, cautions and instructions in this manual cannot cover all the possible conditions and situations that may occur. It must be understood, by the operator, that common sense and cautions are factors that cannot be built into this product but must be exercised by the operator.

BRITPART

The quality parts for Land Rovers

EC Declaration of Conformity

Border Holdings (UK) Ltd

Britpart, The Grove,
Craven Arms, Shropshire,
SY7 8DA, UK

Part Numbers -

**DB12000i, DB9500i, DB9000C, DB8000,
DB6000 & DB2000**

Description - Electric Winches



We hereby declare that above mentioned winches are compliant with the essential requirement of Directive 2006/42/EC, 2006/95/EC and satisfy the standards of ISO 12100-2010, BS EN60204-32:2008 in their application of pulling a load.

Installation

If the winch has a dyneema rope fitted this will have to be removed prior to fitment as the hook is not removable and the rope will have to be threaded through the fairlead once the winch is fixed in place. Refer to operation section on how to replace cable for removal.

Step One

Mount electric winch to the vehicle using nuts and bolts provided. If the provided hardware does not accommodate the installation, use SAE grade 8.8 bolts or higher with torque to 35ft/lbs. It should be aligned and secured to a solid part of the vehicle (front or rear) where the full rated load will be evenly distributed. Also remember that the winch is designed for horizontal not vertical pull.

Step Two

Connect the red (positive) battery cable from the solenoid assembly to the closest screw-down positive (+) terminal to 12 volt battery.

Caution - Battery cables should not be drawn taut. Leave slack for some cable movement.

Step Three

Connect the black (negative) battery cable from solenoid assembly to the closest screw-down negative (-) terminal to 12 volt battery.

Step Four

Test electric winch for proper operation. Refer to the operation section.

Operation

Step One

Lift the female connector cover exposing the electrical switch connector.

Step Two

Insert the switch assembly connector onto the female connector

Step Three

Disengage the clutch by moving cam ring or rotating lever to the OUT position.

Step Four

Grab the cable assembly hook and pull the cable to the desired length then attach to item being pulled.

Caution - Always leave at least 5 turns of cable on the drum. Read over winch safety warning and precautions before continuing.

Step Five

Re-engage the clutch by moving the cam ring or rotating lever to the IN position.

Step Six

While standing aside the vehicle, move the rocker switch backwards and forwards to change direction of the winch, wait for the motor to stop before reversing direction.

Step Seven

When the towing is complete, remove the switch assembly from the female connector and replace the female connector cover.

Cautions

Run the vehicle engine during towing operations to keep the battery charging.

When towing a heavy load, place a blanket or similar over the cable 5 - 6 feet (1.5m - 1.8m) from the hook.

In an emergency switch off the kill switch immediately to cut off the electricity and stop the winch.

Lubrication

No internal lubrication is required as all moving parts inside the winch have been lubricated using high temperature lithium grease at the factory. Lubricate cable every so often using a light penetrating oil.

Rope Assembly Replacement

Step One

Move cam ring to out position

Step Two

Extend cable assembly to its full length. Note how the existing cable is connected to the inside of the drum

Step Three

Remove old cable assembly and attach new one.

Step Four

Retract cable assembly onto cable drum being careful not to allow kinking. The winch rope must be rewound onto drum under a load of at least 500lbs. If this precaution is not taken then the inner wraps will damage the winch rope.

General

Keep vehicle battery in good condition. Make sure the winch battery cable are not drawn taut against any surfaces which could possibly damage them.

Corrosion will reduce performance or may cause a short. Remove and clean the cable connections to the battery fuse box and chassis ground periodically. Cover cables and winch when not in use.

Periodically clean the winch rope with a damp cloth, if necessary a mild detergent may be used.

Cover winch when not in use.

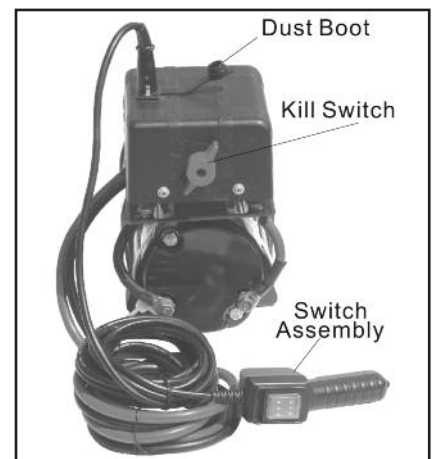

| Symptom | Possible Cause | Suggested Remedy |
|--|--|--|
| Motor does not turn on | Switch assembly not connected properly | Insert switch assembly firmly to the connector |
| | Loose battery cable connection | Tighten the nuts on the cable connectors |
| | Solenoid malfunctioning | Tap solenoid to free contact, applying 12 volts to coil terminal directly. The solenoid will make an audible clicking when activating. |
| | Defective switch assembly | Replace switch assembly |
| | Defective motor | Check for voltage at armature port with switch pressed. If voltage is present then replace motor. |
| | Water has entered motor | Drain and dry. Run in short bursts without load until completely dry. |
| | Kill switch does not turn on | Turn on kill switch |
| Motor runs too hot | Long period of operation | Let winch cool down periodically |
| Motor runs slowly or without normal power | Battery runs down | Recharge battery by running vehicle engine |
| | Insufficient current or voltage | Clean, tighten or replace the connector |
| Motor runs but rope drum does not turn | Clutch (cam ring) not engaged | Push cam ring into IN position. If that does not work, ask a qualified technician to check and repair |
| Motor runs in one direction only | Defective or stuck solenoid | Tap solenoid to free contacts. Repair or replace solenoid. |
| | Defective switch assembly | Replace switch assembly |

Britpart
 Border Holdings (UK) Ltd
 The Grove
 Craven Arms
 Shropshire
 SY7 8DA
 United Kingdom

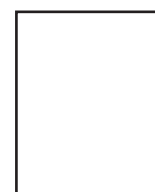

Britpart Limited 24 Month Guarantee



Britpart offers a limited twenty four month guarantee, to the original retailer purchaser, for each new Britpart electric winch against manufacturing defects in workmanship and materials on all mechanical and electrical components.

New cable assemblies are guaranteed against defects in workmanship and materials when received by the retail purchaser. There is no applicable guarantee after initial use.

Guarantee registration cards for each winch must be submitted at the time of purchase or within 30 days by the end user. Guarantee will only be valid for the original purchaser of the winch and installed on the vehicle for which it was originally registered.

Britpart electric winches are intended for recreational self recovery usage. The guarantee is void if the winch is used in commercial/industrial applications.

The obligation under this guarantee, statutory or otherwise, is limited to the replacement or repair at the manufacturers factory or at a point designated by the manufacturer, of such part(s) as shall appear to the manufacturer, upon inspection of such part(s), to have been defective in material or workmanship. This guarantee does not obligate Britpart to bear the cost of labour or transportation charges in connection with the replacement or repair of defective part(s), nor shall it apply to a product upon which repairs or alterations have been made, unless authorised by the manufacturer, or for equipment misused, neglected or improperly installed.

Important Notice

To the fullest extent permitted by applicable law, the following are hereby excluded and disclaimed:

- 1 - All warranties of fitness for a particular purpose
- 2 - All warranties of merchantability
- 3 - All claims for consequential or incidental damages

There are no warranties that extend beyond the description that appears on the face hereof.

To the extent such warranties of fitness or merchantability are deemed to apply to this product, they exist for only so long as the express limited warranty elsewhere set forth is in existence.

Britpart reserves the right to change, alter or improve its products in design, materials or appearance without incurring any obligation to incorporate such changes in products that were previously manufactured.

To submit a guarantee claim contact your Britpart distributor.



GUARANTEE CARD

| | |
|---|--|
| name: _____ | who installed your winch: _____ |
| address: _____ _____ | what vehicle is the winch installed onto - _____ |
| postcode: _____ | make: _____ |
| telephone number: _____ | model: _____ |
| Britpart model number: _____ | year: _____ |
| serial number: _____ | return completed form to: |
| gi number: (found on Britpart sticker on box) _____ | Britpart |
| invoice number: _____ | Border Holdings (UK) Ltd |
| date of invoice: _____ | The Grove |
| where did you purchase winch: _____ | Craven Arms |
| | Shropshire |
| | SY7 8DA |
| | United Kingdom |

Tel: +44 (0) 1588 672711
Fax: +44 (0) 1588 672660
Email: sales@britpart.com
www.britpart.com

BRITPART