

Td5 Fuel Pressure Regulator

BRITPART

The quality parts for Land Rovers

Part Number - LR016318 / LR016319

Removal & Fitting instructions

Removal

1. Release turnbuckles and remove battery cover
2. Disconnect battery earth lead.
3. Remove 3 bolts and remove engine acoustic cover.

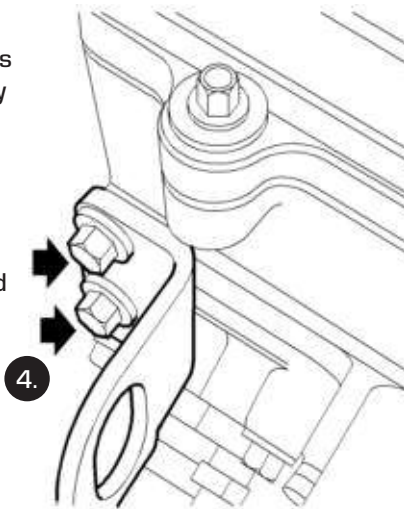

4. Remove 2 bolts and remove engine lifting eye.
5. Position cloth to absorb fuel spillage.

6. Release and disconnect hose from fuel cooler.

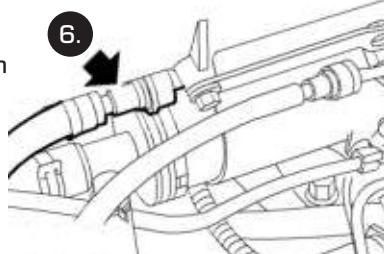

7. Release and disconnect fuel hose from pressure regulator.

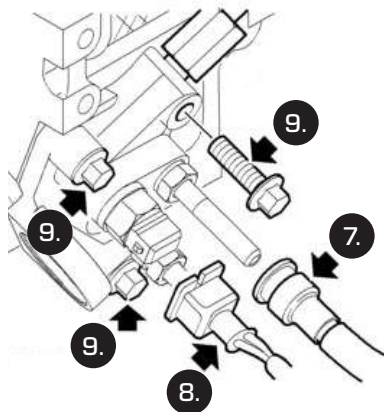

Always fit plugs to open connections to prevent contamination.

8. Disconnect multiplug from fuel temperature sensor.
9. Remove 3 bolts, remove pressure regulator from cylinder head, collect gasket and discard.

10. Remove and discard 'O' ring and fuel filter.

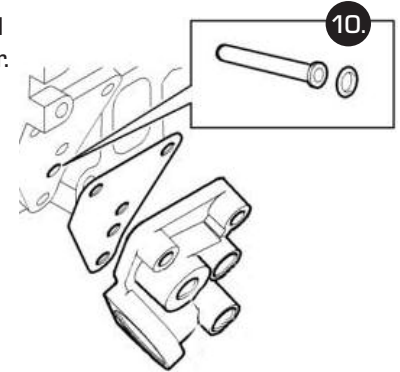

Refit

1. Clean fuel pressure regulator mating face on cylinder head.
2. Clean fuel pipe unions.
3. Fit new fuel filter and 'O' ring.
4. Using a new gasket, position pressure regulator. Use elastic band supplied to hold 3 bolts in place during assembly. (See photo).
5. Tighten bolts to 25 Nm (18 lbf.ft).

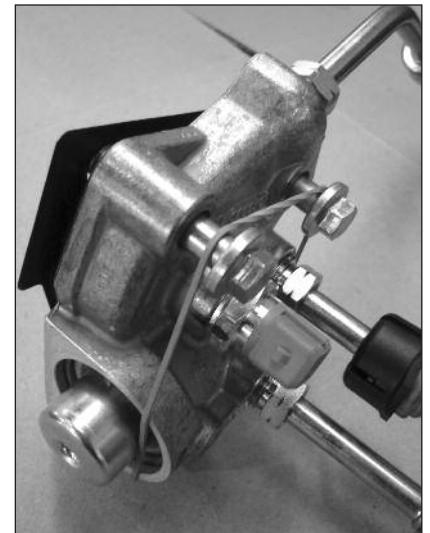

6. Connect multiplug to fuel temperature sensor.
7. Connect fuel hoses to pressure regulator and fuel cooler.
8. **EU3 models:** Using new 'O' ring, connect fuel return hose and tighten union to 25 Nm (18 lbf.ft).
9. Fit engine lifting eye and tighten bolts to 25 Nm (18 lbf.ft).
10. Fit engine acoustic cover and tighten bolts to 10 Nm (6 lbf.ft).
11. Connect battery earth lead.
12. Fit battery cover and secure fixings.
13. Turn ignition on, depress throttle pedal 5 times. Check for leaks.

Disclaimer

These fitting instructions are intended for general guidance only. No responsibility will be accepted for damage to persons, property, equipment or vehicles caused during or arising from the fitment or using of this product. Fitting this item to your vehicle may constitute a vehicle modification and therefore we strongly recommend that you check the product complies with local laws and legislation and always inform the vehicle's insurance company accordingly. Vr. 1.

